

1. Suppose that $U = \{1, 2, 3, 4, 5, 6, 7, 8, 9, 10\}$, $A = \{1, 3, 4, 7\}$, $B = \{2, 4, 6, 8, 10\}$, and $C = \{1, 4, 5, 9\}$, find each of the following sets.

a) $A \cap (B \cup C)$

c) $A \cap \overline{B \cap C}$

e) $\overline{B \cap C}$

g) $\overline{A \cup B}$

b) $(A \cap B) \cup C$

d) $B \cap \overline{C}$

f) $A \cup \overline{B}$

2. Convert the decimal $0.4\overline{2}$ to a fraction of two integers.

3. In a club of 20, we want to elect the president, vice president, and the secretary. How many outcomes are possible in this election?

4. In a club of 20, we want to select a 3-person committee. How many outcomes are possible in this election?

5. Find the measure of an inner angle in a polygon of 24 sides.

6. Consider the figure shown on the picture below.

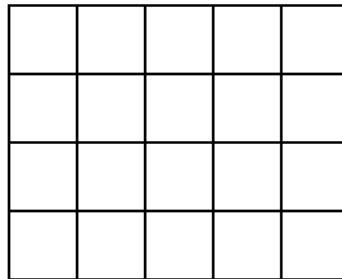

a) Find the number of rectangles on the picture.

b) Find the number of squares on the picture.

7. Consider the set $A = \{1, 2, 3, 4, 5, 6, 7, 8\}$.

a) How many proper subsets does A have?

b) List all 2-element subsets of A .

c) How many 4-element subsets does A have? (You don't have to list them.)

d) We randomly pull two cards, without replacement. What is the probability that the sum of the two numbers is 7?

e) We randomly pull two numbers, with replacement. If one of the numbers is a 2, we receive \$5. If both of the numbers pulled are 2, we receive \$10. Otherwise, we pay \$2. Find the expected value for this game.

8. We wish to buy a used car for \$ 5800. Our bank informs us that there is a finance plan available that consists of a down payment of \$ 500 and 18 monthly payments with an APR of 6.5%. Find the monthly payment under this plan.

9. We wish to buy a used car for \$ 8000. Our bank informs us that there is a finance plan available that consists of a down payment of \$ 500 and 48 monthly payments of \$179.59. Find the APR the bank charges.

10. We have placed \$1000 into a bank account with an annual compound interest rate of 6%. How much money do we have in our account after 25 years, if the bank compounds

a) annually b) monthly c) daily d) continuously

11. Let A be the set of all numbers divisible by 4 and let B be the set of all numbers divisible by 20. Which one is true: $A \subseteq B$ or $B \subseteq A$?

12. We asked 100 students about their courses. 56 take math, 41 take chemistry, and 50 take physics. 22 take math and chemistry, 20 take math and physics, and 30 take chemistry and physics. 15 take all three.
- Draw a Venn diagram depicting these sets.
 - How many people study math or chemistry but not physics?
 - How many people study exactly two of these subjects?
 - We randomly pick a student from this group of 100. What is the probability that we pick someone who takes math?
 - We randomly pick a student from this group of 100. Given that we have picked a student that takes math, what is the probability that s/he also takes chemistry?
 - We randomly pick a student from this group of 100. Given that we have picked a kid that takes chemistry, what is the probability that s/he also takes math?
13. Expand $(a + b)^6$.
14. The height of a solid is 3. Its base is the trapezoid shown on the picture below. Find the volume of the solid.

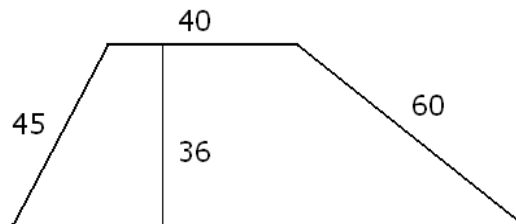

15. Find the present value of \$ 1000 000, hundred years from now. Assume an annual compound interest rate of 6%, compounded
- annually
 - monthly
 - daily
 - continuously
16. We have 10 marbles in a bag: 8 red and 2 green. We randomly pull two marbles, without replacement. If none of the marbles pulled is a green, we pay \$5. Otherwise, we receive \$10 for one green marble pulled and \$30 for two green marbles pulled. Find the expected value for this game.
17. We have 10 marbles in a bag: 8 red and 2 green. We randomly pull two marbles, with replacement. If none of the marbles pulled is a green, we pay \$5. Otherwise, we receive \$10 for one green marble pulled and \$30 for two green marbles pulled. Find the expected value for this game.
18. Compute the volume of the object shown on the picture below. Dimensions are in meters.

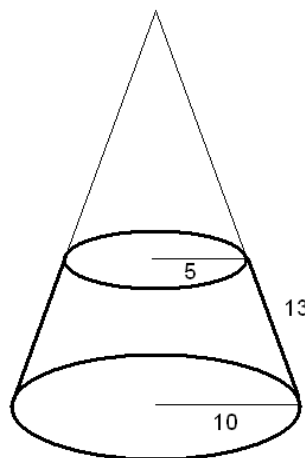

Answers

1.) a) $\{1, 4\}$ b) $\{1, 4, 5, 9\}$ c) $\{1, 3, 7\}$ d) $\{2, 6, 8, 10\}$ e) $\{1, 2, 3, 5, 6, 7, 8, 9, 10\}$

f) $\{1, 3, 4, 5, 7, 9\}$ g) $\{5, 9\}$

2.) $\frac{38}{90}$ 3.) 6840 4.) 1140 5.) 165° 6.) a) 150 b) 40

7.) a) 255 b) see below c) 70 d) $\frac{3}{28}$ e) $-\frac{9}{32} = -0.28125$

$\{1, 2\}$

$\{1, 3\}$ $\{2, 3\}$

$\{1, 4\}$ $\{2, 4\}$ $\{3, 4\}$

$\{1, 5\}$ $\{2, 5\}$ $\{3, 5\}$ $\{4, 5\}$

$\{1, 6\}$ $\{2, 6\}$ $\{3, 6\}$ $\{4, 6\}$ $\{5, 6\}$

$\{1, 7\}$ $\{2, 7\}$ $\{3, 7\}$ $\{4, 7\}$ $\{5, 7\}$ $\{6, 7\}$

$\{1, 8\}$ $\{2, 8\}$ $\{3, 8\}$ $\{4, 8\}$ $\{5, 8\}$ $\{6, 8\}$ $\{7, 8\}$

8.) \$309.81 9.) 7% 10.) a) \$4291.87 b) \$4464.97 c) \$4481.14 d) \$4481.69 11.) $B \subseteq A$

12.) a) see below b) 40 c) 27 d) $\frac{14}{25}$ e) $\frac{11}{28}$ f) $\frac{22}{41}$

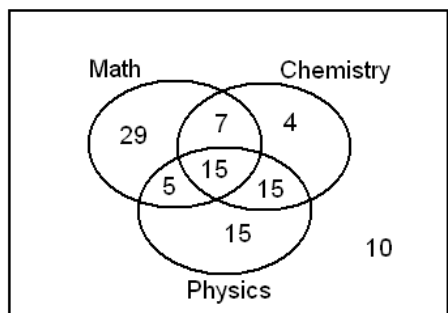

13.) $(a + b)^6 = a^6 + 6a^5b + 15a^4b^2 + 20a^3b^3 + 15a^2b^4 + 6ab^5 + b^6$ 14.) 8370 unit³

15.) a) \$2947.23 b) \$2516.09 c) \$2479.99 d) \$2478.75 16.) $\$ \frac{10}{9} = \$1.\bar{1}$

17.) $\$ \frac{6}{5} = \1.2 18.) $700\pi \text{ m}^3 \approx 2199.11485751 \text{ m}^3$