

## Sample Problems

Solve each of the following equations.

1.)  $\sin x = -\sin^2 x$

2.)  $2 \cos^2 x - 5 \cos x = 3$

3.)  $3(1 - \sin x) = 2 \cos^2 x$

4.)  $\sin x = -\cos x$

5.)  $\tan^2 x = \frac{1}{3}$

6.)  $\cos x \sin x = \cos x$

7.)  $\tan x = \tan^2 x$

8.)  $2 \cos x - \sin x + 2 \cos x \sin x = 1$

9.)  $\cos x = 1 + \sin^2 x$

10.)  $7 \sin x + 5 = 2 \cos^2 x$

## Practice Problems

Solve each of the following equations.

1.)  $1 + \sin x = 2 \cos^2 x$

2.)  $-3 \cos x + 3 = 2 \sin^2 x$

3.)  $\cos^3 x = \cos^2 x$

4.)  $2 \cos^2 x - \cos x = 3$

5.)  $2 \sin^2 x = \cos x + 1$

6.)  $2 \cos^2 x + 3 \sin x = 3$

7.)  $\sec^2 x = 4$

8.)  $\tan x \sin^2 x = \frac{3}{4} \tan x$

9.)  $\frac{1 + \sin x}{\cos x} + \frac{\cos x}{1 + \sin x} = 4$

10.)  $\sin^2 x - \frac{1}{2} \cos x + \cos x \sin^2 x = \frac{1}{2}$

11.)  $\cot x = \cos x$

12.)  $\tan x - \sqrt{2} = \frac{1}{\tan x + \sqrt{2}}$

## Sample Problems - Answers

- 1.)  $x = k_1\pi$  and  $x = -\frac{\pi}{2} + 2k_2\pi$  where  $k_1, k_2 \in \mathbb{Z}$     2.)  $x = \pm\frac{2\pi}{3} + 2k\pi$  where  $k \in \mathbb{Z}$
- 3.)  $x = \frac{\pi}{2} + 2k_1\pi$  and  $x = \frac{\pi}{6} + 2k_2\pi$  and  $x = \frac{5\pi}{6} + 2k_3\pi$  where  $k_1, k_2, k_3 \in \mathbb{Z}$
- 4.)  $x = -\frac{\pi}{4} + k\pi$  where  $k \in \mathbb{Z}$     5.)  $x = \pm\frac{\pi}{6} + k\pi$  where  $k \in \mathbb{Z}$     6.)  $x = \frac{\pi}{2} + k\pi$  where  $k \in \mathbb{Z}$
- 7.)  $x = \frac{\pi}{4} + k_1\pi$  and  $x = k_2\pi$  where  $k_1, k_2 \in \mathbb{Z}$
- 8.)  $x = \pm\frac{\pi}{3} + 2k_1\pi$  and  $x = -\frac{\pi}{2} + 2k_2\pi$  where  $k_1, k_2 \in \mathbb{Z}$     9.)  $x = 2k\pi$  where  $k \in \mathbb{Z}$
- 10.)  $x = -\frac{\pi}{6} + 2k_1\pi$  and  $x = \frac{7\pi}{6} + 2k_2\pi$  where  $k_1, k_2 \in \mathbb{Z}$

## Practice Problems - Answers

- 1.)  $x = \frac{\pi}{6} + 2k_1\pi$  and  $x = \frac{5\pi}{6} + 2k_2\pi$  and  $x = \frac{3\pi}{2} + 2k_3\pi$  where  $k_1, k_2, k_3 \in \mathbb{Z}$
- 2.)  $x = \pm\frac{\pi}{3} + 2k_1\pi$  and  $x = 2k_2\pi$  where  $k_1, k_2 \in \mathbb{Z}$     3.)  $x = \frac{\pi}{2} + k_1\pi$ , and  $x = 2k_2\pi$ , where  $k_1, k_2 \in \mathbb{Z}$
- 4.)  $x = \pi + 2k\pi$  where  $k \in \mathbb{Z}$     5.)  $x = \pm\frac{\pi}{3} + 2k_1\pi$  and  $x = \pi + 2k_2\pi$  where  $k_1, k_2 \in \mathbb{Z}$
- 6.)  $x = \frac{\pi}{2} + 2k_1\pi$ ,  $x = \frac{\pi}{6} + 2k_2\pi$ , and  $x = \frac{5\pi}{6} + 2k_3\pi$  where  $k_1, k_2, k_3 \in \mathbb{Z}$
- 7.)  $x = \pm\frac{\pi}{3} + k\pi$  where  $k \in \mathbb{Z}$     8.)  $x = k\pi$ ,  $x = \frac{\pi}{3} + 2k\pi$ , and  $x = \frac{2\pi}{3} + 2k\pi$  where  $k_1, k_2, k_3 \in \mathbb{Z}$
- 9.)  $x = \pm\frac{\pi}{3} + 2k\pi$  where  $k \in \mathbb{Z}$     10.)  $x = \pm\frac{\pi}{4} + k_1\pi$ , and  $x = \pi + 2k_2\pi$  where  $k_1, k_2 \in \mathbb{Z}$
- 11.)  $x = \frac{\pi}{2} + k\pi$  where  $k \in \mathbb{Z}$     12.)  $x = \pm\frac{\pi}{3} + k\pi$  where  $k \in \mathbb{Z}$

## Sample Problems - Solutions

1.)  $\sin x = -\sin^2 x$

Solution:

$$\begin{array}{rcl} \sin x & = & -\sin^2 x & \text{add } \sin^2 x \\ \sin^2 x + \sin x & = & 0 & \text{factor out } \sin x \\ \sin x (\sin x + 1) & = & 0 & \end{array}$$

$$\begin{array}{rcl} \sin x = 0 & \text{or} & \sin x + 1 = 0 \\ & & \sin x = -1 \end{array}$$

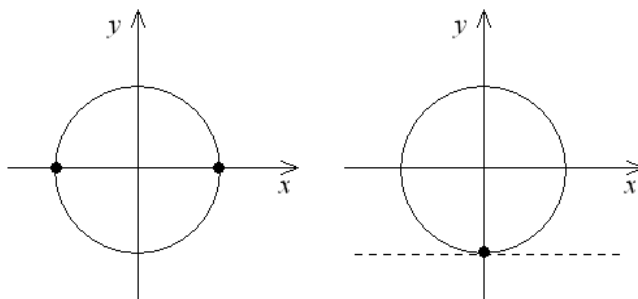

If  $\sin x = 0$ , then  $x = k\pi$  where  $k \in \mathbb{Z}$ . If  $\sin x + 1 = 0$ , then  $\sin x = -1$  and so  $x = -\frac{\pi}{2} + 2k\pi$  where  $k \in \mathbb{Z}$ .

2.)  $2 \cos^2 x - 5 \cos x = 3$

Solution: This equation is quadratic in  $\cos x$ . If helps, we may introduce a new variable,  $a = \cos x$ .

$$\begin{array}{rcl} 2 \cos^2 x - 5 \cos x & = & 3 & \text{Let } a = \cos x \\ 2a^2 - 5a & = & 3 \\ 2a^2 - 5a - 3 & = & 0 \\ (2a + 1)(a - 3) & = & 0 & \implies a = -\frac{1}{2} \text{ or } a = 3 \\ \cos x = -\frac{1}{2} & \text{or} & \cos x = 3 \end{array}$$

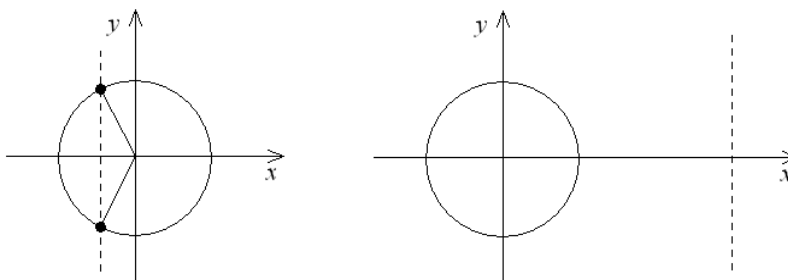

The solution of  $\cos x = -\frac{1}{2}$  is  $x = \pm \frac{2\pi}{3} + 2k\pi$ . There is no solution of  $\cos x = 3$ .

$$3.) \quad 3(1 - \sin x) = 2 \cos^2 x$$

Solution: After we write  $\cos^2 x = 1 - \sin^2 x$ , this equation will become quadratic in  $\sin x$ .

$$\begin{aligned} 3(1 - \sin x) &= 2 \cos^2 x && \cos^2 x = 1 - \sin^2 x \\ 3(1 - \sin x) &= 2(1 - \sin^2 x) && \text{distribute} \\ 3 - 3 \sin x &= 2 - 2 \sin^2 x && \text{add } 2 \sin^2 x \\ 2 \sin^2 x - 3 \sin x + 3 &= 2 && \text{subtract 2} \\ 2 \sin^2 x - 3 \sin x + 1 &= 0 && \text{factor} \\ (2 \sin x - 1)(\sin x - 1) &= 0 \\ \sin x &= \frac{1}{2} && \text{or} && \sin x = 1 \end{aligned}$$

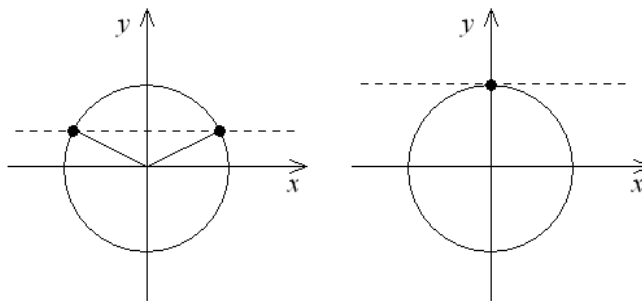

The solution of  $\sin x = \frac{1}{2}$  is  $x = \frac{\pi}{6} + 2k\pi$  and  $x = \frac{5\pi}{6} + 2k\pi$  where  $k \in \mathbb{Z}$ . The solution of  $\sin x = 1$  is  $x = \frac{\pi}{2} + 2k\pi$  where  $k \in \mathbb{Z}$ .

$$4.) \quad \sin x = -\cos x$$

Solution: Since neither  $\sin x$  nor  $\cos x$  is squared, it is difficult to eliminate either one of them. There are several methods to solve this equation. One method involves squaring both sides of the two equations and then eliminating one trigonometric function in terms of the other. Notice that, because of the squaring, this method creates extraneous solutions so we have to carefully check our solution. The method presented here is a clever alternative.

Case 1. If  $\cos x = 0$

If  $\cos x = 0$ , then clearly  $\sin x = \pm 1$  since  $\sin x = \pm \sqrt{1 - \cos^2 x}$ . Then  $x$  is clearly not a solution of the equation  $\sin x = -\cos x$ .

Case 2. If  $\cos x \neq 0$ , then we can divide by it.

$$\sin x = -\cos x \quad \text{divide by } \cos x \neq 0$$

$$\frac{\sin x}{\cos x} = -1$$

$$\tan x = -1$$

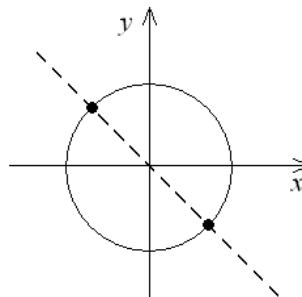

The solution is  $x = -\frac{\pi}{4} + k\pi$  where  $k \in \mathbb{Z}$ .

$$5.) \tan^2 x = \frac{1}{3}$$

Solution:

$$\tan^2 x = \frac{1}{3}$$

$$\tan x = \pm \frac{1}{\sqrt{3}}$$

$$\tan x = \frac{1}{\sqrt{3}} \quad \text{or} \quad \tan x = -\frac{1}{\sqrt{3}}$$

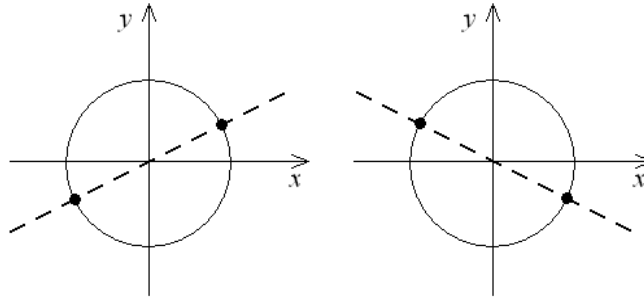

The solution of  $\tan x = \frac{1}{\sqrt{3}}$  is  $x = \frac{\pi}{6} + k\pi$  where  $k \in \mathbb{Z}$ , and the solution of  $\tan x = -\frac{1}{\sqrt{3}}$  is  $x = -\frac{\pi}{6} + k\pi$  where  $k \in \mathbb{Z}$ .

$$6.) \cos x \sin x = \cos x$$

Solution:

$$\begin{aligned} \cos x \sin x &= \cos x && \text{subtract } \cos x \\ \cos x \sin x - \cos x &= 0 && \text{factor out } \cos x \\ \cos x (\sin x - 1) &= 0 \\ \cos x = 0 &\quad \text{or} \quad \sin x - 1 = 0 \\ \cos x = 0 &\quad \text{or} \quad \sin x = 1 \end{aligned}$$

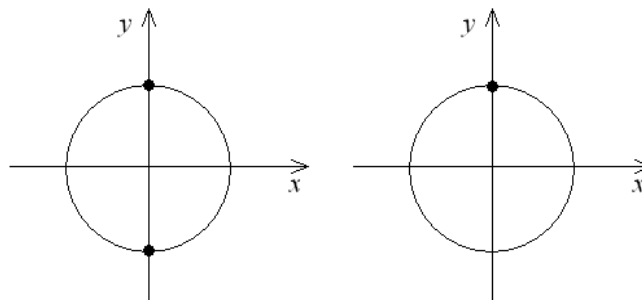

The solution of  $\cos x = 0$  is  $x = \pm \frac{\pi}{2} + 2k\pi$  where  $k \in \mathbb{Z}$  (notice this can be written simpler, as  $x = \frac{\pi}{2} + k\pi$ ) and the solution of  $\sin x = \frac{\pi}{2} + 2k\pi$  where  $k \in \mathbb{Z}$ . As the picture already indicates, the second case does not bring in any new solutions; if  $\sin x = 1$  then of course also  $\cos x = 0$ . The final answer is  $x = \frac{\pi}{2} + k\pi$  where  $k \in \mathbb{Z}$ .

7.)  $\tan x = \tan^2 x$

Solution:

$$\begin{aligned} \tan x &= \tan^2 x && \text{subtract } \tan x \\ 0 &= \tan^2 x - \tan x && \text{factor out } \tan x \\ 0 &= \tan x (\tan x - 1) \\ \tan x &= 0 && \text{or} && \tan x = 1 \end{aligned}$$

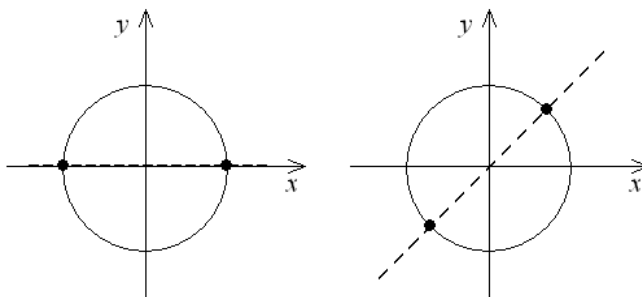

The solution of  $\tan x = 0$  is  $x = k\pi$  where  $k \in \mathbb{Z}$ , and the solution of  $\tan x = 1$  is  $x = \frac{\pi}{4} + k\pi$  where  $k \in \mathbb{Z}$ .

8.)  $2 \cos x - \sin x + 2 \cos x \sin x = 1$

Solution:

$$\begin{aligned} 2 \cos x - \sin x + 2 \cos x \sin x &= 1 && \text{subtract 1} \\ 2 \cos x \sin x + 2 \cos x - \sin x - 1 &= 0 && \text{factor by grouping} \\ 2 \cos x (\sin x + 1) - (\sin x + 1) &= 0 \\ (2 \cos x - 1) (\sin x + 1) &= 0 \\ 2 \cos x - 1 = 0 && \text{or} && \sin x + 1 = 0 \\ \cos x = \frac{1}{2} && \text{or} && \sin x = -1 \end{aligned}$$

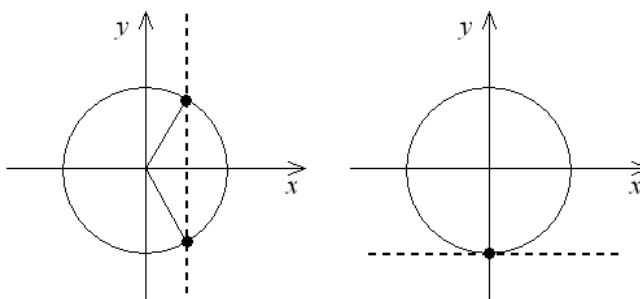

If  $\cos x = \frac{1}{2}$ , then  $x = \pm \frac{\pi}{3} + 2k\pi$  where  $k \in \mathbb{Z}$ . And if  $\sin x = -1$ , then  $x = -\frac{\pi}{2} + 2k\pi$  where  $k \in \mathbb{Z}$ .

9.)  $\cos x = 1 + \sin^2 x$

Solution:

$$\begin{aligned} \cos x &= 1 + \sin^2 x & \sin^2 x &= 1 - \cos^2 x \\ \cos x &= 1 + 1 - \cos^2 x & \text{add } \cos^2 x & \\ \cos^2 x + \cos x &= 2 & \text{subtract } 2 & \\ \cos^2 x + \cos x - 2 &= 0 & \text{factor} & \\ (\cos x - 1)(\cos x + 2) &= 0 & & \end{aligned}$$

$\cos x = 1$

or

$\cos x = -2$

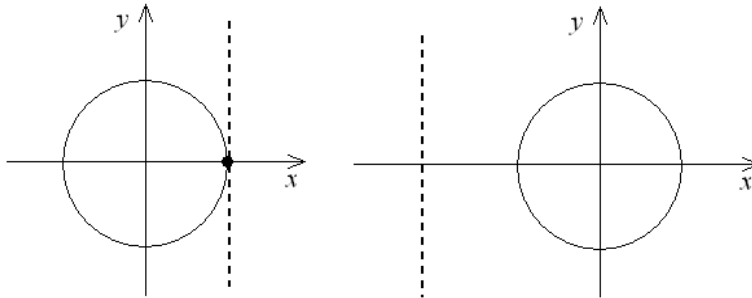

The solution of  $\cos x = 1$  is  $x = 2k\pi$  where  $k \in \mathbb{Z}$ , and the equation  $\cos x = -2$  has no solution.

10.)  $7 \sin x + 5 = 2 \cos^2 x$

Solution:

$$\begin{aligned} 7 \sin x + 5 &= 2 \cos^2 x & \cos^2 x &= 1 - \sin^2 x \\ 7 \sin x + 5 &= 2(1 - \sin^2 x) & \text{distribute} & \\ 7 \sin x + 5 &= 2 - 2 \sin^2 x & \text{add } 2 \sin^2 x & \\ 2 \sin^2 x + 7 \sin x + 5 &= 2 & \text{subtract } 2 & \\ 2 \sin^2 x + 7 \sin x + 3 &= 0 & \text{factor} & \\ (2 \sin x + 1)(\sin x + 3) &= 0 & & \end{aligned}$$

$\sin x = -\frac{1}{2}$

or

$\sin x = -3$

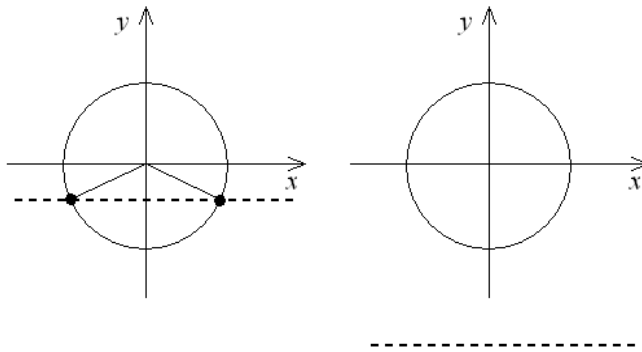

The solution of  $\sin x = -\frac{1}{2}$  is  $x = -\frac{\pi}{6} + 2k\pi$  and  $x = -\frac{5\pi}{6} + 2k\pi$  where  $k \in \mathbb{Z}$ , and the equation  $\cos x = -3$  has no solution.

For more documents like this, visit our page at <https://teaching.martahidegkuti.com> and click on Lecture Notes. E-mail questions or comments to [mhidegkuti@ccc.edu](mailto:mhidegkuti@ccc.edu).